

GT-750-A Series Spring Loaded AC LVDT Linear Position Sensor

Features

- Spring loaded probe
- AC LVDT
- Stroke lengths from ± 0.1 to ± 0.3 inches
- Non-Linearity better than $\pm 0.5\%$ of FS
- Stainless steel housing sealed to IP61

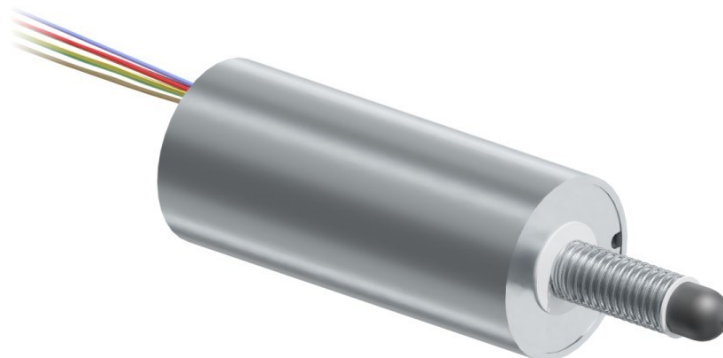

Applications

- Laboratory R&D Materials Testing
- Industrial Gauging Test Stands
- Factory Automation

Overview

The HGSi GT-750-A series Spring Loaded AC Linear Variable Differential Transformer (LVDT) Position Sensors are used to monitor and track the linear motion or position of a target. These spring-loaded ruggedized sensors are ideal for use in industrial and laboratory applications including automotive R&D, motorsports, industrial, motion control, medical, military and aerospace.

The sensor shaft has an external helical spring and is guided by nylon sleeve bearings. These swaged-end sensors are constructed entirely of stainless steel and are resistant to dust and temperature. The coil windings are sealed using an epoxy potting compound providing excellent protection against shock and vibration.

The GT-750-A series will operate with most any conventional differential input AC LVDT signal conditioner, but operation with ratiometric signal conditioning is not recommended. HGSi offers a full line of compatible AC LVDT signal conditioners. Please contact us for a recommendation.

Specifications

Input Voltage:	3 Vrms (nominal)
Input Frequency:	2.5 kHz to 3.0 kHz
Linearity Error:	$\leq \pm 0.5\%$ of FSO typical
Null Voltage:	0.5% of FS
Repeatability:	0.01% of FS
Hysteresis:	0.01% of FS
Bandwidth:	3 Hz (mechanical)
Operating Temperature:	-30 to +105°C (-20 to +220°F)
Thermal Coefficient:	$< -0.03\%/^{\circ}\text{C}$ of FS ($< -0.015\%/^{\circ}\text{F}$ of FS)
Humidity:	90% RH
Housing:	Stainless steel
Contact Tip:	AGD #9 hardened tool steel, chrome plated, #4-48 thread, interchangeable
Mating Connector:	Amphenol PT06A-10-6S(SR) or equivalent
Life Expectancy:	> 100 million cycles
Shock Rating:	100g, 11 mS
Vibration Tolerance:	20 g to 2 kHz
IP Rating:	IEC IP61
Country of Manufacture:	Made in the USA

GT-750-A Series Spring Loaded AC LVDT Linear Position Sensor

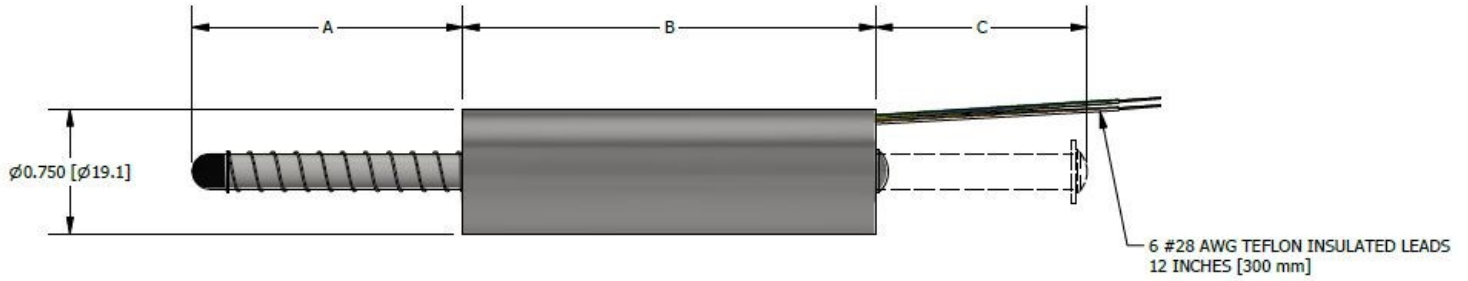

Specifications

All dimensions in inches [mm]

	GT-750-A-100	GT-750-A-200	GT-750-A-300
Measuring Range (in) [mm]	± 0.100 [± 2.5]	± 0.200 [± 5.0]	± 0.300 [± 7.5]
Sensitivity (mV/V/0.001 in) [mm]	3.8 [152]	2.1 [83]	2.1 [83]
Pretravel (in) [mm]	0.23 [5.8]	0.23 [5.8]	0.33 [8.3]
Overtravel (in) [mm]	0.34 [8.6]	0.22 [5.5]	0.85 [21.5]
Dimension A (in) [mm]	1.75 [44.5]	2.5 [63.5]	2.5 [63.5]
Dimension B (in) [mm]	0.79 [20.1]	0.83 [21.1]	1.64 [41.6]
Dimension C (in) [mm]	0.43 [10.9]	0.56 [14.1]	1.28 [32.5]
Spring Rate (lb/in) (nominal)	0.23	0.23	0.14
Weight (oz) [g]	1.9 [52]	2.3 [64]	2.4 [68]

Ordering Information

Model	Measuring Range	Options
GT-750-A	- □ □ □	- □ □ □
	100 ± 0.100 inches 200 ± 0.200 inches 300 ± 0.300 inches	Consult Factory for custom designs

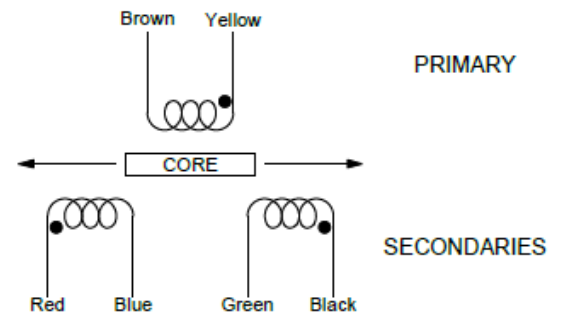

NOTE: CONNECT GREEN AND BLUE FOR DIFFERENTIAL OPERATION

Ordering Example

GT-750-A-100: AC LVDT, ± 0.100 inch Measuring Range

