

Input: 100 Ω to 10,000 Ω Bridge, 0.5 mV/V to 120 mV/V, 1-10 VDC Excitation
Output: 0-1 V to ±10 V or 0-2 mA to 4-20 mA (Sink or Source), Non-Isolated

[Quick Link: api-usa.com/4058](http://api-usa.com/4058)

- Adjustable Excitation Power Supply
- One Minute Setup for Hundreds of I/O Ranges
- Removable Plugs for Faster Installation
- Input and Output LoopTracker® LEDs
- Output Test or Calibration Resistor Options



Connect mA Output for Sink or Source 1 2 3 4 Removable Plugs
 Hundreds of Range Selections 5 6 7 8

Applications

- Load Cell Weighing Systems and Scales
- Strain Gauge Pressure Sensors and Transducers
- Tanks, Scales, Extruder Melt Pressure, Crane Loads

Strain Gauge Input Ranges

Minimum range: 0 to 5 mV
 Maximum range: 0 to 1200 mV
 Minimum sensitivity: 0.5 mV/V
 Maximum sensitivity: 120 mV/V

Millivolt output range is determined by the sensitivity of the sensor (mV/V) and the excitation voltage applied.

mV/V sensitivity X excitation voltage = total mV range

Input Impedance

1 MΩ typical

Common Mode Rejection

100 dB minimum

Calibration Resistor Options

M01 option: Switch with calibration resistor inside module. Specify resistor value.
 M02 option: Switch for external (load cell) calibration resistor.

Excitation Voltage

Maximum output: 10 VDC maximum at 30 mA
 Drive capability: One 100 Ω to 10,000 Ω bridge at 10 VDC
 Switch selectable: 0-10 VDC in 1 V increments
 Fine adjustment: ±2.5% via multitrurn potentiometer
 Stability: ±0.01% per °C

LoopTracker

Variable brightness LEDs for input/output loop level and status

DC Output Ranges

	Minimum	Maximum
Voltage:	0-1 VDC	0-10 VDC (10 mA max)
Bipolar Voltage:	±1 VDC	±10 VDC (±10 mA max)
Current:	0-2 mADC	4-20 mADC
	20 V compliance, 1000 Ω at 20 mA	

Output Calibration

Multi-turn zero and span potentiometers
 ±15% of span adjustment range typical
 Zero offset switch: ±100% of span in 15% increments

Output Test

Sets output to test level when pressed
 Potentiometer adjustable 0-100% of span
 Not available with M01 or M02 options

Output Ripple and Noise

Less than 10 mVrms ripple and noise

Linearity

Better than ±0.1% of span

Ambient Temperature Range and Stability

-10°C to +60°C operating ambient
 Better than ±0.02% of span per °C stability

Response Time

70 milliseconds typical (14.3 Hz)
 DF option: 10 millisecond response time typical (100 Hz)
 Contact factory for custom response times

Housing and Connectors

IP 40, requires installation in panel or enclosure
 For use in Pollution Degree 2 Environment
 Mount vertically to a 35 mm DIN rail
 Four 4-terminal removable connectors, 14 AWG max wire size

Power

Standard: 85-265 VAC, 50/60 Hz or 60-300 VDC
 D option: 9-30 VDC (either polarity) or 10-32 VAC
 Power: 2 to 5 Watts depending on number of load cells



[Applications Link](http://api-usa.com/apps)
api-usa.com/apps

Free Factory I/O Setup!

1 Minute Setup!

Dimensions

0.89" W x 4.62" H x 4.81" D
 22.5 mm W x 117 mm H x 122 mm D
 Height includes connectors

Description

The APD 4058 accepts an input from a strain gauge, bridge type sensor, load cell, or pressure transducer.

It filters, amplifies, and converts the resulting millivolt signal into the selected DC voltage or current output that is linearly related to the input. The output is not electrically isolated.

The adjustable excitation power supply generates a stable source of voltage to drive your sensor.

Input, output, excitation and zero offset are field configurable, via external rotary and slide switches.

Offsets up to ±100% of span can be used to cancel sensor offsets or non-zero deadweights (taring).

Sink/Source Versatility

For maximum versatility the APD 4058 milliamp output can be selectively wired for sinking or sourcing. This allows connection to any type of mA input receiving device.

Model	Input	Output	Power
APD 4058	Field configurable. Specify the following if factory is to set switches Bridge mV/V or mV range Excitation voltage	Field configurable. Specify following if factory is to set switches Output range Output type (V or mA)	85-265 VAC or 60-300 VDC
APD 4058 D			9-30 VDC or 10-32 VAC

Options—add to end of model number

- M01** Switch with built-in calibration resistor. Specify resistor value.
- M02** Switch for external calibration resistor.
- R** Input/output reversal, such as 20-4 mA output
- DF** 10 millisecond response time, or consult factory.
DF option will cause output noise levels to be greater than standard specifications.
- U** Conformal coating for moisture resistance



Connect One 100 Ω to 10,000 Ω Load Cell 9 10 11 12

Universal Power 13 14 15 16

See Wiring Diagrams on Page 3

LoopTracker

API exclusive features include two LoopTracker LEDs (green for input, red for output) that vary in intensity with changes in the process input and output signals. These provide a quick visual picture of your process loop at all times and can greatly aid in saving time during initial startup and/or troubleshooting.

Output Test

An API exclusive feature includes the test button to provide a fixed output (independent of the input) when held depressed. The output test button greatly aids in saving time during initial startup and/or troubleshooting. The test output level is potentiometer adjustable from 0 to 100% of output span.

The output test is not available with the M01 or M02 options. A calibration resistor switch replaces the test button.

Accessory—order as separate line item

- API BP4** Spare removable 4 terminal plug, black

Precautions

WARNING! All wiring must be performed by a qualified electrician or instrumentation engineer. See diagram for terminal designations and wiring examples. Consult factory for assistance.

WARNING! Avoid shock hazards! Turn signal input, output, and power off before connecting or disconnecting wiring, or removing or installing module.

Précautions

ATTENTION! Tout le câblage doit être effectué par un électricien ou ingénieur en instrumentation qualifié. Voir le diagramme pour désignations des bornes et des exemples de câblage. Consulter l'usine pour assistance.

ATTENTION! Éviter les risques de choc! Fermez le signal d'entrée, le signal de sortie et l'alimentation électrique avant de connecter ou de déconnecter le câblage, ou de retirer ou d'installer le module.

Range Selection

It is generally easier to select ranges before installing the module on the DIN rail. The tables list available settings for excitation voltages, ranges and offsets. Any custom range settings will be listed on the module's serial number label

Rotary switches and a slide switches on the side of the module are used to select I/O ranges to match your application.

- Switch A: Excitation voltage
- Switch B: Input range
- Switch C: Input offset
- Switch D: Output range
- Switch E: Set to "V" for voltage output or Set to "I" for current output

Determine how much output in millivolts the load cell will produce at full load. Multiply the manufacturer's mV/V sensitivity specification by the applied excitation voltage.

For example, a load cell rated for 3 mV/V sensitivity using 10 VDC excitation will produce an output of 0 to 30 mV for load variations from 0 to 100%.

3 mV/V sensitivity X 10 VDC excitation = 30 mV range

Excitation Voltage Setup Switch A

Refer to the sensor manufacturer's recommendations to determine what excitation voltage to use.

Set Excitation rotary switch A to desired excitation voltage. See table below.

After installation the excitation fine adjust potentiometer may be used to precisely trim this voltage, if desired.

Excitation	Switch A
10 V	A
9 V	9
8 V	8
7 V	7
6 V	6
5 V	5
4 V	4
3 V	3
2 V	2
1 V	1
0 V	0

I/O Range Selection B, C, D, E

- From the table below, find the rotary switch combination that matches your I/O ranges and set rotary switches B, C, and D.
- Set switch E to "V" for voltage output or "I" for current output.
- For ranges that fall between the listed ranges use the next highest setting and trim the output signal with the zero and span potentiometers as described in the Calibration section.

Offset Switch C

Offset switch C allows canceling or taring of non-zero deadweights or other sensor offsets such as:

- Compensate for tare weights or scale deadweight to get zero output when a load is on the platform.
- Compensate for low-output sensors (e.g., less than 1 mV/V) that may have large zero offsets. Switch C can realign the zero control so it has enough range to produce the desired zero output.
- Raising the offset to allow calibration of bipolar sensors such as ±10 mV.
- Lowering the offset to compensate for elevated input ranges such as 10-20 mV.

- Switch C does not interact with any other switch and is the only switch needed to correct zero offsets. Its only purpose is to adjust or cancel effects of the low end of the input range not corresponding nominally to 0 mV. Setting this switch to "0" results in no offset.
- To RAISE the output zero, rotate switch C from "1" thru "7", until the Zero control can be set for your application.
- To LOWER the output zero, rotate switch C from "9" thru "F", until the Zero control can be set for your application.
- If switch positions are changed, repeat the calibration procedure on the last page.

Offset % of Span	Switch C
105%	7
90%	6
75%	5
60%	4
45%	3
30%	2
15%	1
0%	0
-15%	9
-30%	A
-45%	B
-60%	C
-75%	D
-90%	E
-105%	F

Output	0-1 V	0-2 V	0-4 V	1-5 V	0-5 V	0-8 V	2-10 V	0-10 V	±5 V	±10 V	0-2 mA	0-4 mA	0-8 mA	2-10 mA	0-10 mA	0-16 mA	4-20 mA	0-20 mA
Switches	BCDE	BCDE	BCDE	BCDE	BCDE	BCDE	BCDE	BCDE	BCDE	BCDE	BCDE	BCDE	BCDE	BCDE	BCDE	BCDE	BCDE	BCDE
Input	BCDE	BCDE	BCDE	BCDE	BCDE	BCDE	BCDE	BCDE	BCDE	BCDE	BCDE	BCDE	BCDE	BCDE	BCDE	BCDE	BCDE	BCDE
±2.5 mV	1B0V	1B1V	1B2V	192V	1B3V	1B5V	195V	1B6V	1B8V	1B9V	1B0I	1B1I	1B2I	192I	1B3I	1B5I	195I	1B6I
0-5 mV	1E0V	1E1V	1E2V	1C2V	1E3V	1E5V	1C5V	1E6V	1E8V	1E9V	1E0I	1E1I	1E2I	1C2I	1E3I	1E5I	1C5I	1E6I
±5 mV	9B0V	9B1V	9B2V	992V	9B3V	9B5V	995V	9B6V	9B8V	9B9V	9B0I	9B1I	9B2I	992I	9B3I	9B5I	995I	9B6I
0-10 mV	9E0V	9E1V	9E2V	9C2V	9E3V	9E5V	9C5V	9E6V	9E8V	9E9V	9E0I	9E1I	9E2I	9C2I	9E3I	9E5I	9C5I	9E6I
±10 mV	3B0V	3B1V	3B2V	392V	3B3V	3B5V	395V	3B6V	3B8V	3B9V	3B0I	3B1I	3B2I	392I	3B3I	3B5I	395I	3B6I
±12.5 mV	5B0V	5B1V	5B2V	592V	5B3V	5B5V	595V	5B6V	5B8V	5B9V	5B0I	5B1I	5B2I	592I	5B3I	5B5I	595I	5B6I
±15 mV	DB0V	DB1V	DB2V	D92V	DB3V	DB5V	D95V	DB6V	DB8V	DB9V	DB0I	DB1I	DB2I	D92I	DB3I	DB5I	D95I	DB6I
0-20 mV	3E0V	3E1V	3E2V	3C2V	3E3V	3E5V	3C5V	3E6V	3E8V	3E9V	3E0I	3E1I	3E2I	3C2I	3E3I	3E5I	3C5I	3E6I
±20 mV	BB0V	BB1V	BB2V	B92V	BB3V	BB5V	B95V	BB6V	BB8V	BB9V	BB0I	BB1I	BB2I	B92I	BB3I	BB5I	B95I	BB6I
0-25 mV	5E0V	5E1V	5E2V	5C2V	5E3V	5E5V	5C5V	5E6V	5E8V	5E9V	5E0I	5E1I	5E2I	5C2I	5E3I	5E5I	5C5I	5E6I
±25 mV	0B0V	0B1V	0B2V	092V	0B3V	0B5V	095V	0B6V	0B8V	0B9V	0B0I	0B1I	0B2I	092I	0B3I	0B5I	095I	0B6I
0-30 mV	DE0V	DE1V	DE2V	DC2V	DE3V	DE5V	DC5V	DE6V	DE8V	DE9V	DE0I	DE1I	DE2I	DC2I	DE3I	DE5I	DC5I	DE6I
0-40 mV	BE0V	BE1V	BE2V	BC2V	BE3V	BE5V	BC5V	BE6V	BE8V	BE9V	BE0I	BE1I	BE2I	BC2I	BE3I	BE5I	BC5I	BE6I
0-50 mV	0E0V	0E1V	0E2V	0C2V	0E3V	0E5V	0C5V	0E6V	0E8V	0E9V	0E0I	0E1I	0E2I	0C2I	0E3I	0E5I	0C5I	0E6I
±50 mV	8B0V	8B1V	8B2V	892V	8B3V	8B5V	895V	8B6V	8B8V	8B9V	8B0I	8B1I	8B2I	892I	8B3I	8B5I	895I	8B6I
±60 mV	FB0V	FB1V	FB2V	F92V	FB3V	FB5V	F95V	FB6V	FB8V	FB9V	FB0I	FB1I	FB2I	F92I	FB3I	FB5I	F95I	FB6I
0-100 mV	8E0V	8E1V	8E2V	8C2V	8E3V	8E5V	8C5V	8E6V	8E8V	8E9V	8E0I	8E1I	8E2I	8C2I	8E3I	8E5I	8C5I	8E6I
±100 mV	2B0V	2B1V	2B2V	292V	2B3V	2B5V	295V	2B6V	2B8V	2B9V	2B0I	2B1I	2B2I	292I	2B3I	2B5I	295I	2B6I
0-120 mV	FE0V	FE1V	FE2V	FC2V	FE3V	FE5V	FC5V	FE6V	FE8V	FE9V	FE0I	FE1I	FE2I	FC2I	FE3I	FE5I	FC5I	FE6I
±125 mV	4B0V	4B1V	4B2V	492V	4B3V	4B5V	495V	4B6V	4B8V	4B9V	4B0I	4B1I	4B2I	492I	4B3I	4B5I	495I	4B6I
±150 mV	CB0V	CB1V	CB2V	C92V	CB3V	CB5V	C95V	CB6V	CB8V	CB9V	CB0I	CB1I	CB2I	C92I	CB3I	CB5I	C95I	CB6I
0-200 mV	2E0V	2E1V	2E2V	2C2V	2E3V	2E5V	2C5V	2E6V	2E8V	2E9V	2E0I	2E1I	2E2I	2C2I	2E3I	2E5I	2C5I	2E6I
±200 mV	AB0V	AB1V	AB2V	A92V	AB3V	AB5V	A95V	AB6V	AB8V	AB9V	AB0I	AB1I	AB2I	A92I	AB3I	AB5I	A95I	AB6I
0-250 mV	4E0V	4E1V	4E2V	4C2V	4E3V	4E5V	4C5V	4E6V	4E8V	4E9V	4E0I	4E1I	4E2I	4C2I	4E3I	4E5I	4C5I	4E6I
0-300 mV	CE0V	CE1V	CE2V	CC2V	CE3V	CE5V	CC5V	CE6V	CE8V	CE9V	CE0I	CE1I	CE2I	CC2I	CE3I	CE5I	CC5I	CE6I
0-400 mV	AE0V	AE1V	AE2V	AC2V	AE3V	AE5V	AC5V	AE6V	AE8V	AE9V	AE0I	AE1I	AE2I	AC2I	AE3I	AE5I	AC5I	AE6I
0-1000 mV	6E0V	6E1V	6E2V	6C2V	6E3V	6E5V	6C5V	6E6V	6E8V	6E9V	6E0I	6E1I	6E2I	6C2I	6E3I	6E5I	6C5I	6E6I
0-1200 mV	EE0V	EE1V	EE2V	EC2V	EE3V	EE5V	EC5V	EE6V	EE8V	EE9V	EE0I	EE1I	EE2I	EC2I	EE3I	EE5I	EC5I	EE6I

M01 Option: Internal Calibration Resistor

The APD 4058 M01 has a user-specified internal calibration resistor. A switch on the front of the module allows switching of the APD's internal calibration resistor in or out of the circuit. The sensor manufacturer should provide the percentage of full-scale output for the transducer when using the APD's internal resistor for calibration.

M02 Option: Load Cell Calibration Resistor

The APD 4058 M02 has provisions for a load cell with its own calibration resistor. A switch on the front of the module allows switching of the load cell internal calibration resistor in or out of the circuit.

Refer to the load cell manufacturer's specifications and the wiring diagram when connecting a transducer with its own internal calibration resistor.

The transducer's calibration resistor wires are connected to terminals 5 and 11 on the APD 4058.

If the transducer only has one calibration resistor wire, connect it to terminal 5.

Input

Refer to strain gauge manufacturer's data sheet for wire color-coding and identification. Polarity must be observed when connecting inputs.

CAUTION: Do not miswire the load cell and never short the excitation leads together. This will cause internal damage to the module.

No Sense Leads

When no sense leads are used, jumper terminals 6 and 12.

With Sense Leads

Some bridges or load cells have one or two sense leads. Sense leads allow the APD 4058 to compensate for leadwire resistance effects. Connect the sense leads if used. Polarity must be observed.

Never jumper terminals 6 and 12 when using sense leads.

Output

Polarity must be observed when connecting the signal output.

If your device accepts a current input, determine if it provides power to the current loop or if it must be powered by the APD module. Use a multi-meter to check for voltage at the device's input terminals. Typical voltage may be 9-24 VDC.

Type of Device for Output	- Term.	+ Term.
mA (current) input device that powers the current loop. Switch E set to "I".	2 (-)	3 (+)
mA (current) input device that is passive. APD module provides the loop power. Switch E set to "I".	3 (-)	4 (+20 V)
Measuring/recording device accepts a voltage input. Switch E set to "V".	3 (-)	4 (+)

Module Power

Check model/serial number label for module operating voltage to make sure it matches available power. Connect power last.

When using DC power, either polarity is acceptable, but for consistency with similar API products, positive (+) can be wired to terminal 13 and negative (-) can be wired to terminal 16.

CAUTION: To maintain full isolation avoid wiring DC power supplies in common with output and unit power.

Mounting to a DIN Rail

Install module vertically on a 35 mm DIN rail in a protective enclosure away from heat sources. Do not block air flow. Allow 1" (25 mm) above and below housing vents for air circulation.

1. Tilt front of module downward and position against DIN rail.
2. Clip lower mount to bottom edge of DIN rail.
3. Push front of module upward until upper mount snaps into place.

Removal

1. Push up on the bottom back of the module.
2. Tilt front of module downward to release upper mount from top edge of DIN rail.
3. The module can now be removed from the DIN rail.

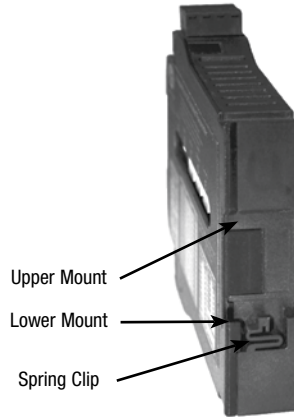

To avoid damage to the module, do not make any connections to unused terminals

Wire terminal torque
0.5 to 0.6 Nm or
4.4 to 5.3 in-lbs

Shield wires should be grounded at one end only

Colors shown are an example only. See manufacturer's specifications for wiring designations.

To maintain full isolation avoid combining power supplies in common with input, output, or unit power.

API maintains a constant effort to upgrade and improve its products. Specifications are subject to change without notice. See api-usa.com for latest product information. Consult factory for your specific requirements.



WARNING: This product can expose you to chemicals including nickel, which are known to the State of California to cause cancer or birth defects or other reproductive harm. For more information go to www.P65Warnings.ca.gov

Output Wiring

Current sinking output switch E set to "I"
External device provides power to output loop

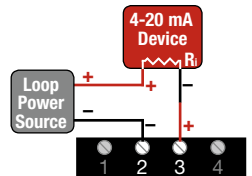

Current sourcing output switch E set to "I"
+20 V at terminal 4

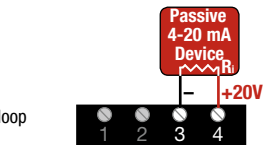

Module powers mA output loop

Voltage output switch E set to "V"

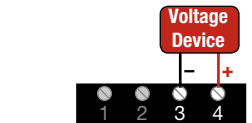

No Sense Leads

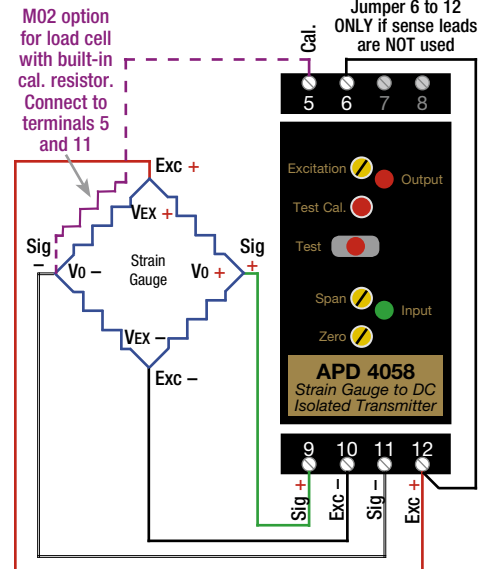

With Sense Leads

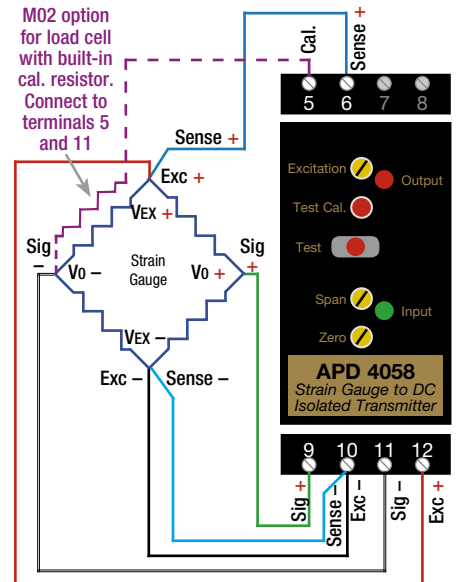

Module Power

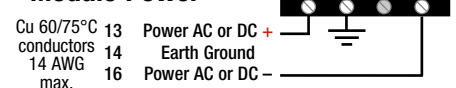

Basic Calibration

The Zero, Span, and Excitation potentiometers are used to calibrate the output. This calibration procedure does not account for offsets or tare weights. If your system has an offset, tare weight or deadweight, refer to the Offset Switch procedure.

Note: Perform the following calibration procedure any time switch settings are changed.

To achieve optimum results, the system should be calibrated using an accurate bridge simulator, pressure calibrator, or calibration weights depending on the application.

1. Apply power to the module and allow a minimum 20 minute system warm up time.
2. Using an accurate voltmeter across terminals 10 and 12, adjust the Excitation voltage potentiometer on front of the APD 4058 for the exact voltage desired.
3. With the input set at zero or the minimum, adjust the front Zero pot for a zero or low-end output (for example, 4 mA for a 4-20 mA output or -10 V with a ±10V output).
4. The zero pot may also be adjusted for a zero reading on the output display instrumentation, e.g. control system or process indicator. Adjusting the zero pot this way eliminates calibration errors in the display instrumentation.
5. Set the input at maximum, and then adjust the Span pot for the exact maximum output desired. The Span control should only be adjusted when the input signal is at its maximum.

Output Test Function

Models with the M01 or the M02 option do not have a Test function. With either of these options the Test Cal. potentiometer is non-functional.

When the Test button is depressed it will drive the output with a known good signal that can be used as a diagnostic aid during initial start-up or troubleshooting. When released, the output will return to normal.

The Test Cal. potentiometer can be used to set the test output to the desired level. It is factory set to approximately 50% output. It is adjustable from 0 to 100% of the output span. Press and hold the Test button and adjust the Test Cal. potentiometer for the desired output level.

Calibration with Resistor Options M01 or M02

Use this calibration procedure if your APD 4058 was ordered with a calibration resistor or if your sensor has its own internal calibration resistor.

Note: Perform the following calibration procedure any time switch settings are changed.

The M01 option uses a resistor installed internally in the APD 4058. The resistance is specified by the transducer manufacturer.

The M02 option is specified when the transducer incorporates an internal calibration resistor. The transducer must be connected per the manufacturer's specifications.

The sensor manufacturer should provide the percentage of full-scale output for the transducer when using a calibration resistor. This is often 80% of maximum output.

1. Apply power to the module and allow a minimum 20 minute system warm up time.
2. Using an accurate voltmeter across terminals 10 and 12, adjust the Excitation voltage potentiometer on front of the APD 4058 for the exact voltage desired.
3. With the input set at zero or the minimum, adjust the Zero potentiometer on front of the APD 4058 for a zero or low-end output (for example, 4 mA for a 4-20 mA output).
4. The zero pot may also be adjusted for a zero reading on the output display instrumentation, e.g. control system or process indicator. Adjusting the zero pot this way eliminates calibration errors in the display instrumentation.
5. Set the APD 4058 Test toggle switch to the Test position. The calibration resistor is switched into the circuit to unbalance the bridge.
6. Adjust the span pot to the for the % output specified by the transducer manufacturer. This is often 80% of maximum output.
7. Return the Test switch to the opposite position and readjust the zero pot if necessary.

Operation

Strain gauges and load cells are normally passive devices that are commonly referred to as "bridges" due to their four-resistor Wheatstone bridge configuration. These sensors require a precise excitation source to produce an output that is directly proportional to the load, pressure, etc. that is applied to the sensor.

The exact output of the sensor (measured in millivolts) is determined by the sensitivity of the sensor (mV/V) and the excitation voltage applied.

An additional input, the sense lead, monitors the voltage drop in the sensor leads and automatically compensates the excitation voltage at the module in order to maintain a constant excitation voltage at the sensor.

The APD 4058 provides the excitation voltage to the sensors and receives the resulting millivolt signal in return. This input signal is filtered and amplified, then offset, if required, and passed to the output stage. Depending on the output configuration selected, a DC voltage or current output is generated.

GREEN LoopTracker® Input LED – Provides a visual indication that a signal is being sensed by the input circuitry of the module. It also indicates the input signal level by changing in intensity as the process changes from minimum to maximum. If the LED fails to illuminate, or fails to change in intensity as the process changes, this may indicate a problem with module power or signal input wiring.

RED LoopTracker Output LED – Provides a visual indication that the output signal is functioning. It becomes brighter as the input and the corresponding output change from minimum to maximum. For current outputs, the RED LED will only light if the output loop current path is complete. For either current or voltage outputs, failure to illuminate or a failure to change in intensity as the process changes may indicate a problem with the module power or signal output wiring.

Diagnostic Voltage Measurements

Using a meter with at least 10 megaohm input impedance, measure the voltage coming from the strain gauge at the locations shown. Sensitivity is measured in mV/V.

Positive Meter Lead	Negative Meter Lead	Meter Reading No pressure/load	Meter Reading Full pressure/load
+ Exc.	- Exc.	Excitation Voltage	Excitation Voltage
+ Sig.	- Exc.	+ ½ Excitation Voltage	½ Excitation Voltage + (½ x Excitation Voltage x Sensitivity)
- Sig.	- Exc.	+ ½ Excitation Voltage	½ Excitation Voltage - (½ x Excitation Voltage x Sensitivity)
+ Sig.	- Sig.	Zero Volts	Excitation Voltage x Sensitivity

Typical Wiring Color Codes for Load Cells

Always consult manufacturer. Exceptions and/or custom wire colors exist!

Manufacturer	+ Exc.	- Exc.	+ Signal	- Signal	Shield	+ Sense	- Sense
A & D	Red	White	Green	Blue	Yellow		
Allegany	Green	Black	White	Red	Bare		
American/Amcell	Green	Black	White	Red	Bare		
Artech	Red	Black	Green	White	Bare		
Beowulf	Green	Black	White	Red	Bare		
BLH	Green	Black	White	Red	Yellow		
Cardinal	Green	Black	White	Red	Bare		
Celtron	Red	Black	Green	White	Bare		
Digi Matex	Red	White	Green	Yellow	Silver		
Dillon (DQ+)	Green	White	Black	Red	Orange		
Electroscale	Red	Black	Green	White	Bare		
Entran	Red	Black	Yel./Grn.	White	Bare		
EverGreen	Green	Black	White	Red	Bare		
Flintec	Green	Black	White	Red	Yellow		
Force Measurement	Red	Black	Green	White	Bare		
Futek	Red	Black	Green	White	Bare		
General Sensor	Red	Black	Green	White	Bare		
GSE	Red	Black	White	Green	Bare		
HBM	Green	Black	White	Red	Yellow		
HBM (PLC/SBE)	Red	Black	Green	White	Yellow		
Interface	Red	Black	Green	White	Bare		
Kubota	Red	White	Green	Blue	Yellow		
LeBow	Red	Black	Green	White	Bare		
Mettler Toledo	White	Blue	Green	Black	Orange	Yellow	Red
National Scale	Green	Black	White	Red	Yellow		
NCI	Red	Black	White	Green	Bare	Yellow	Blue

Manufacturer	+ Exc.	- Exc.	+ Signal	- Signal	Shield	+ Sense	- Sense
Nikkei	Red	Black	Green	White	Bare		
OmegaDyne	Red, D, F	Blk., C, E	Green A	White B	Bare		
Pennsylvania	Orange	Blue	Green	White	Bare		
Philips	Red	Blue	Green	Gray	Bare		
Presage Promotion	Blue	White	Red	Black	Yellow		
Revere	Green	Black	White	Red	Orange		
Revere	Red	Black	Green	White	Orange		
Rice Lake	Red	Black	Green	White	Bare		
Sensortronic	Red	Black	Green	White	Bare		
Sensortronic (col.)	Green	Black	White	Red	Bare		
Sensotec/Honeywell	Red	Black	White	Green	Bare		
Sentran	Red	Black	Green	White	Bare		
SMD	Red	Black	White	Green	Bare		
Strainsert	Red	Black	Green	White	Bare		
Stellar STI	Red	Black	White	Green	Bare		
Stellar STI	Red	Black	Green	White	Bare		
Stellar STI	A	D	B	C	Bare		
Stellar STI	A, B	C, D	F	E	Bare		
T-Hydrionics	Red	Black	Green	White	Bare		
Tedea Huntleigh	Green	Black	Red	White	Bare	Blue	Brown
Thames Side	Red	Blue	Green	Yellow	Bare		
Toledo	Green	Black	White	Red	Yellow		
Totalcomp	Red	Black	Green	White	Bare		
Transducer Tech.	Red A	Black D	Green C	White B	Bare G		
Transducers Inc.	Red	Black	Green	White	Orange		
Weigh-Tronix	Green	Black	White	Red	Or./Wh.	Yellow	Blue