

# Instruction Manual

## Single Channel Type K Thermocouple Amplifier



TCA-MS-K-1

# Instruction Manual - TCA-MS-K-1 Thermocouple Amplifier

## Wiring Schematic:

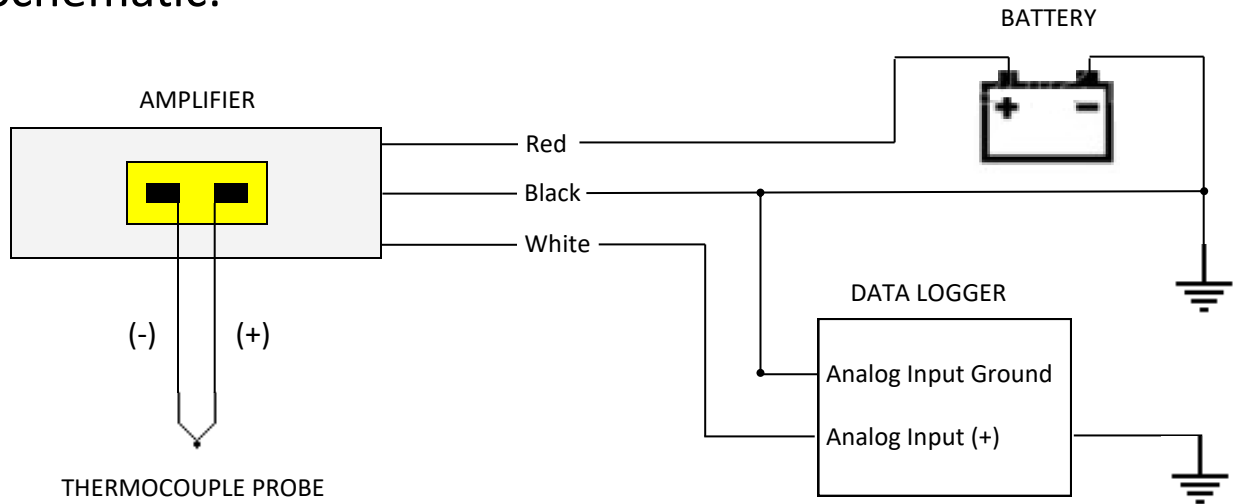

## Wiring the Thermocouple Mating Connector:



Use a **Type K** Thermocouple **Mini** Connector (with flat pins)  
 The Sensor Connection p/n: CON-MP-MINI-K

Type K Thermocouple International Color Codes:

Country Made:	USA & Canada*	Japan	Germany	British	France
(+) Positive	YELLOW	RED	RED	BROWN	YELLOW
(-) Negative	RED	WHITE	GREEN	BLUE	PURPLE

\* Note: All EGT and CHT sensors from The Sensor Connection follow USA color codes

## Analog Output; Thermocouple Channel:

Scale Factor (°C)	4 mV/°C (0 to +1250°C)
Scale Factor (°F)	2.2 mV/°F (+32 to +2282°F)

Volts	°C	°F
0.00	0	32
0.10	25	77
0.20	50	122
0.30	75	167
0.40	100	212
0.50	125	257
0.60	150	302
0.70	175	347
0.80	200	392
0.90	225	437
1.00	250	482
1.10	275	527
1.20	300	572
1.30	325	617
1.40	350	662
1.50	375	707
1.60	400	752

Volts	°C	°F
1.70	425	797
1.80	450	842
1.90	475	887
2.00	500	932
2.10	525	977
2.20	550	1022
2.30	575	1067
2.40	600	1112
2.50	625	1157
2.60	650	1202
2.70	675	1247
2.80	700	1292
2.90	725	1337
3.00	750	1382
3.10	775	1427
3.20	800	1472
3.30	825	1517

Volts	°C	°F
3.40	850	1562
3.50	875	1607
3.60	900	1652
3.70	925	1697
3.80	950	1742
3.90	975	1787
4.00	1000	1832
4.10	1025	1877
4.20	1050	1922
4.30	1075	1967
4.40	1100	2012
4.50	1125	2057
4.60	1150	2102
4.70	1175	2147
4.80	1200	2192
4.90	1225	2237
5.00	1250	2282

**Multiplier:**

Temperature (°C) = Volts \* 250

Temperature (°F) = (Volts \* 450) + 32

**Example:**

Output from amplifier = 2.00 Volts

2.00 Volts \* 250 = 500°C

(2.00 Volts \* 450) + 32 = 932°F

# Instruction Manual - TCA-MS-K-1 Thermocouple Amplifier

## Specifications:

Input Specifications	
Number of Input Channels	1
Thermocouple Type	K (ungrounded)
Measuring Range	+32 to +2282°F (0 to +1250°C)
Input Connection	Mini Thermocouple Jack
Input Resistance	60k Ω
Max Bias Voltage on Input	5.8 V
Analog Output Specifications	
Number of Output Channels	1
Analog Output Range	0 to +5 VDC
Scale Factor (nominal)	2.2 mV / °F (4.0 mV / °C)
Resolution	Infinite
Response Time	> 1 mS
Non-Linearity	< +/- 2% FRO
Output Cable	3 conductor, 22 AWG, PVC jacket, 6 foot long

Power Specifications	
Supply Voltage	10 to 32 VDC
Current Draw	< 50 mA
Environmental Specifications	
Operating Temperature Range	+32 to +158°F (0 to +70°C)
Humidity	85% Max. RH (non-condensing)
Liquid & Dust Protection	IP51
Mechanical Specifications	
Housing Dimensions (L x W x H)	2.5 x 2.5 x 0.9 inch
Weight	3 oz (85 g)

## Housing Dimensions:

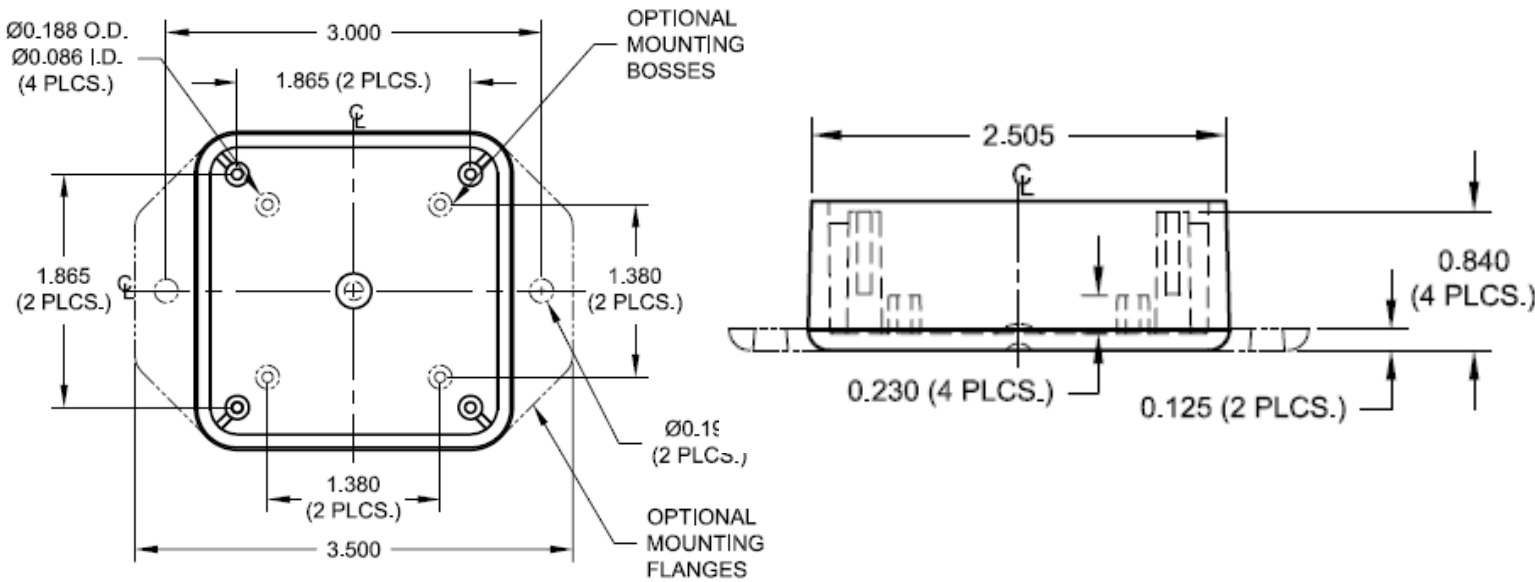

# Instruction Manual - TCA-MS-K-1 Thermocouple Amplifier

## Danger

- Ensure that the vehicle will remain stationary and turn off the engine before installing this product. Failure to do so could result in a fire, and could make the vehicle move during installation.
- Remove the key from the ignition and disconnect the negative (-) battery terminal prior to installation of this product. Failure to do so could result in a fire caused by an electrical short circuit.
- Take care not to install this product in a way that interferes with safety equipment such as seat belts and air bag systems or vehicle operation equipment such as engine controls, steering wheel or brake systems. Interference with normal operation of the vehicle can result in an accident or fire.
- Solder or use a solderless connector for wiring connections and make sure connections are insulated. In areas where there could be tension or sudden impacts on the wiring, safeguard the wiring with corrugated tubing or other shock absorbent material. Accidental shorts can cause fires.

## Warning

- Carefully consider the installation location and driver's operation of the product before installation. Do not install the product where it interrupts driving and the safety devices of vehicle such as the air bag system. Be sure not to install the unit where it could fall. Improper installation or operation could cause the product to fall and damage the vehicle or cause serious danger by impeding driving.
- Do not disassemble or modify this product. Such actions can not only damage or destroy the product but will also void the warranty.
- Do not perform installation of this product immediately after the engine has been switched off. The engine and exhaust system are extremely hot at this time and can cause burns if touched.
- Ensure that the wiring of this product does not have an adverse impact on the other wiring of the vehicle. Any controlling devices or other electronic components of the vehicle could be damaged.
- Please keep children and infants away from the installation area. Children may swallow small parts or be injured in other ways.

## Caution

- Insulate any unused wires. If any wires or connectors loosen during installation, please make sure they are correctly reattached.
- Dropping any of the components of this product will result in damage to the product.
- Excessive force on switches/terminals may result in damage to the product.
- Use only the wires provided. If additional wires are required, use the same of quality and gauge wire as is provided with the kit.
- Do not attach wires on the body of the vehicle or engine parts as this may result in damage to the product.
- Install wires away from ignition and also radio signal frequency interference as this could cause the gauges to malfunction.
- Do not place wires near the engine, exhaust pipe or turbine. It may result in damage or fusion of wires.
- Make sure the waterproof processing is done when routing wires in the engine compartment.
- When installing the sensor, do not bend the wire near the sensor body.
- Wear gloves to avoid burns when soldering and cuts when working with wiring.
- Do not share a single fuse with multiple gauges. Every gauge requires an independent fuse.
- Install amplifier away from hot or wet places.
- Do not pull the wires out of connectors forcefully. The connectors may be broken and the wires may be cut. When pulling out the wires, press the lock firmly and unclip the locks of connectors.

# Instruction Manual - TCA-MS-K-1 Thermocouple Amplifier

## 12 MONTH LIMITED WARRANTY

The Sensor Connection LLC (TSC) warrants to the consumer that all TSC products will be free from defects in material and workmanship for a period of twelve (12) months from date of the original purchase. Products that fail within this 12 month warranty period will be repaired or replaced at TSC's option to the consumer, when it is determined by TSC that the product failed due to defects in material or workmanship. This warranty is limited to the repair or replacement of parts in the TSC instruments. In no event shall this warranty exceed the original purchase price of the TSC instruments nor shall TSC be responsible for special, incidental or consequential damages or costs incurred due to the failure of this product. Warranty claims to TSC must be transportation prepaid and accompanied with dated proof of purchase. This warranty applies only to the original purchaser of product and is non-transferable. All implied warranties shall be limited in duration to the said 12 month warranty period. Breaking the instrument seal, improper use or installation, accident, water damage, abuse, unauthorized repairs or alterations voids this warranty. TSC disclaims any liability for consequential damages due to breach of any written or implied warranty on all products manufactured or supplied by TSC.

FOR SERVICE SEND TO:

**The Sensor Connection**

42690 Woodward Avenue, Suite 200, Bloomfield Hills, MI 48304 USA

(248) 636-1515

email us at: [sales@thesensorconnection.com](mailto:sales@thesensorconnection.com)

[www.thesensorconnection.com](http://www.thesensorconnection.com)